



Surefire 709 Sentry
Owner's Manual

August 4, 2008

TABLE OF CONTENTS

	page
1 Quick Set Up	1
1.1 Connections	1
2 Modes of Operation and Indicators	4
2.1 Battery Charging	4
2.2 Charger Characteristic	4
2.3 Back Up Power	4
3 Recommended Installation Configuration	5
4 Battery Considerations	6
4.1 Battery Selection	6
4.2 Battery Condition	6
4.3 Determining Operating Time	6
5 Installation Test	7
6 Trouble Shooting Guide	7
7 Warranty & Repair	8
Warranty Card	9
8 General Description & Catalog	10

1 Quick Set Up

Model SF 709 is packaged in fully assembled form. After removing the unit from its packaging and ensuring that it has suffered no damage in shipment, it is important to observe the following instructions to ensure proper sequencing when interconnecting the SF 709, battery bank, and primary power line.

The SF 709 is comprised of two major modules arranged in a two tier format. The top module houses the battery charger, command circuitry, and transfer switch. The lower module is the inverter section.

1.1 Connections

Tools Required - 1 flat blade screw driver (1/4 in. wide)

Figure 1 shows the front view of the unit.

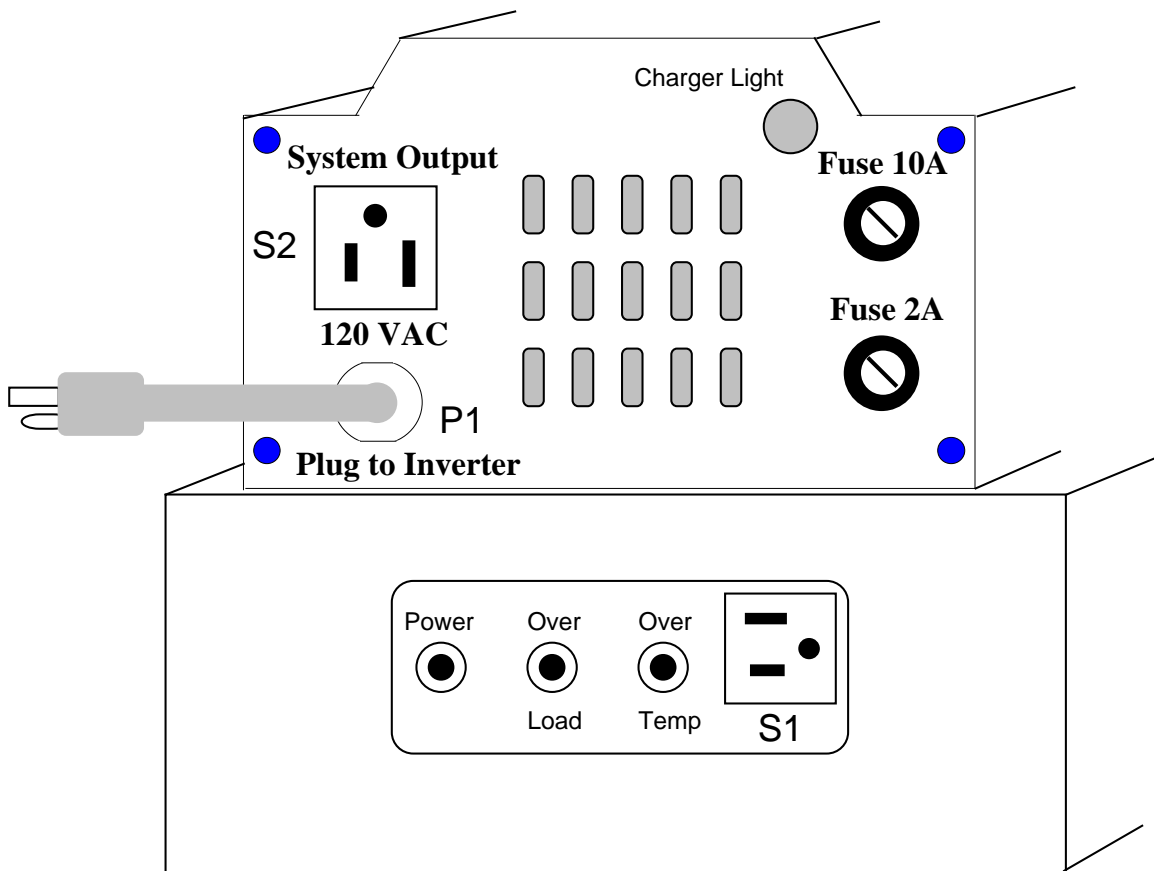

Figure 1

A) Plug the short power cord P1 of the top module into the socket S1 of the Inverter.

Figure 2 shows the rear view of the unit.

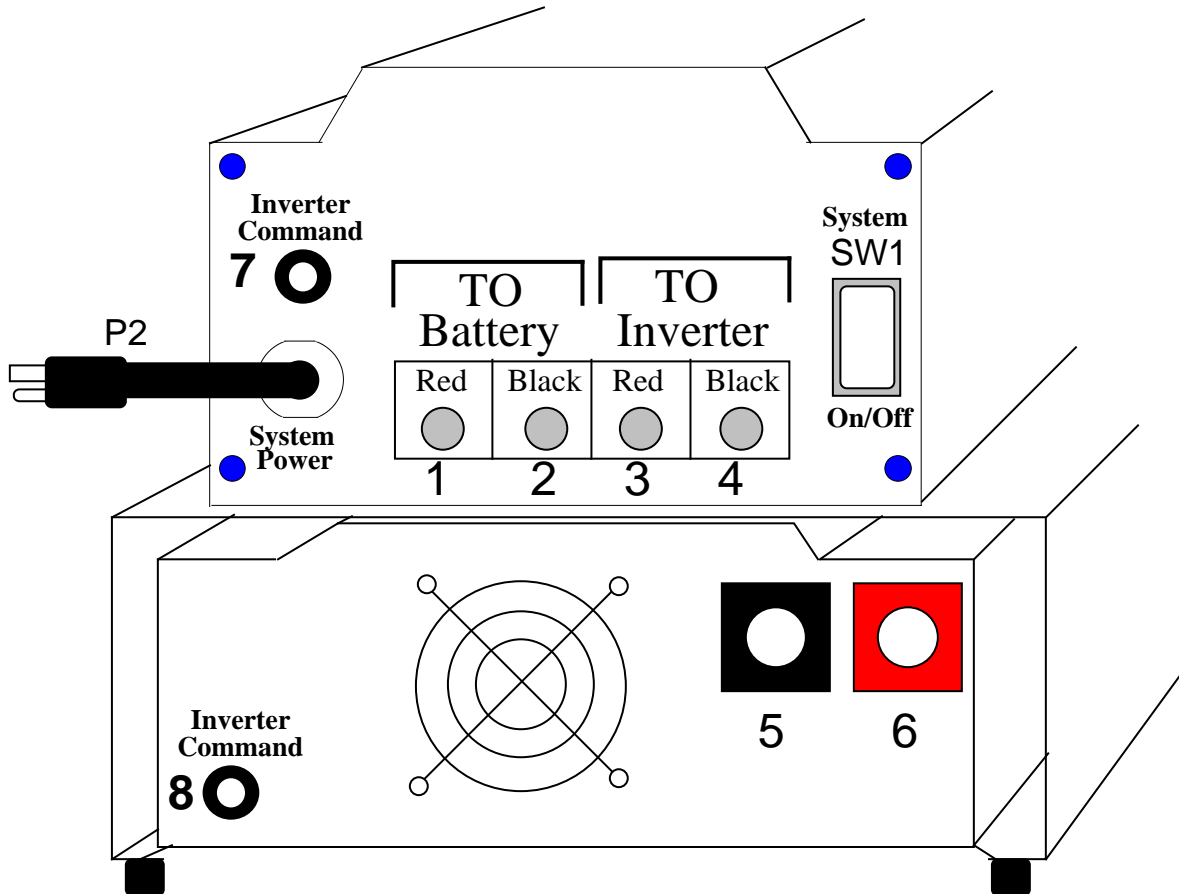

Figure 2

- B) Connect position 4 of Top Module to position 5 of Bottom Module (inverter) using 5 inch long Black 6 gauge cable provided.
- C) Connect position 3 of Top Module to position 6 of Bottom Module (inverter) using 7 inch long Red 6 gauge wire provided.
- D) Using 6 foot long 6 gauge battery cable pair provided hook up the battery. Insert the RED and BLACK cable ends into terminals 1 and 2 respectively of the top module. **PRIOR TO THE INSERTIONS MAKE SURE THAT THE INSULATION AT THE ENDS OF THE CABLES ARE STRIPPED BY AT LEAST 3/8 OF AN INCH. AFTER EACH INSERTION TIGHTEN THE TERMINAL BLOCK SCREW SECURELY.**

Connect the Ring Terminal of the Red battery cable to the positive terminal of the battery. Connect the other end to Position 1 of the Top Module.

Similarly, connect the Ring Terminal of the Black battery cable to the negative terminal of the battery. Connect the other end to Position 2 of the Top Module.

DOUBLE CHECK CONNECTIONS (B) THROUGH (D) AS ANY CONNECTION ERRORS MAY RESULT IN MALFUNCTION OR PERMANENT DAMAGE.

E) Connect the appliance to be powered to receptacle S2 shown in Figure 1.

F) Plug the main power cord P2 (The Black One) into a source of AC power.

G) Turn master rocker switch SW1 shown in Figure 2 to the “ON” position by pressing on the lower part of the rocker and exposing its top red portion. This step energizes the charger, transfer switch, and enables the inverter command.

H) Locate the 7 inch long black connector wire (inverter command wire) which is terminated at both ends with a banana plug. Insert one end into jack (7) and the other into jack (8) both shown in Figure 2. This last step enables the inverter. **Should you wish to disable your SF 709 for storage or battery servicing, it is important that you not only turn off the master switch SW1 in Figure 2, but also disconnect one end of the inverter command cable. Otherwise your inverter will continue to function until it discharges the battery completely.**

2 Modes of Operation and Indicators (Figure #1)

2.1 Battery Charging

The SF 709 is equipped with a three stage “smart” charger, which is housed in the Top Module. When charging a battery that has just experienced total discharge the SF 709 will supply up to 11A under current limit conditions. During such a state the charger light (Fig #1) will illuminate and will remain so during most of the charging cycle. It will gradually become dimmer as the battery tends toward its full charge. By the time the battery arrives at the “float charge” zone the charger light will be completely off. In the float charge zone the charger remains off and supplies small bursts of charge current from time to time to ensure that the battery remains at full charge in readiness for the next power outage.

It can take from several hours to days for the charger light to transition from the dim to the off state. This time will depend on the size of the battery or battery bank being recharged. Typically for a fully discharged 100 A-hr battery it will take 15 hours.

2.2 Charger Characteristics

The charger characteristics make it suitable to charging lead acid or AGM batteries.

2.3 Back Up Power

When line power is removed, either by utility power interruption or by turning off master switch SW1 (Figure #2), the charger light of the top module (Figure #1) will extinguish. At the same time the green led on the led array of the bottom module (inverter) will light. This is the one marked “Power”. In this stage the inverter fan will remain “OFF” until its internal temperature rises and it is switched “ON by its thermostat.

Should the SF 709 be overloaded during the back up power session, the middle “Over Load” red led on the inverter led array will illuminate. At this time the inverter will cease to operate. The inverter will reset in either of two conditions.

- 1) Manually, by temporarily disconnecting one end of the inverter command wire. See para. (H) in the section above on **Connections**.
- 2) Automatically, once utility power is restored.

Should the SF 709 experience restricted airflow the “Over Temp” red led will illuminate and the inverter will shut down. The inverter fan will continue to circulate air until the over temperature condition is eliminated. The inverter will reset automatically.

3 THE RECOMMENDED INSTALLATION SETUP

The SF 709 and its associated battery bank should be near to one another. However it is not recommended that liquid batteries should be located in living quarters or near sources of heat e.g. the heating appliance (kerosene or pellet stove). Ideally the back up system should be installed in a dry garage, crawl space or basement. The 120 VAC utility power can then be transmitted through proper electrical cabling or extension cords to the heating appliance. Other characteristics of the installation location to take into account are:

- a) **Close to 3-prong AC outlet** - within 5 feet.
- b) **Dry** - In a location where no liquids, (water or other chemicals) can drip or splash onto the unit.
- c) **Safe**- Do not install the SF 709 in the same compartment as batteries or any flammable liquids such as gasoline or kerosene. (Some batteries, while being charged, can emit hydrogen gas requiring the battery to have some ventilation.)
- d) **Ventilated** - Do not block either the fan or the exit air ports of the SF 709. For example, if the unit were to be mounted on a carpeted floor, the carpet fibers will block air from the exit ports. Therefore the mounting surface should be flat and smooth. **Do not place objects on top of the unit.** Allow at least 2 inches of air clearance for both sides and top of the unit. Any compartment containing the SF 709 system must have some ventilation - it should not be airtight.
- e) **Close to battery** - The SF 709 comes with battery cables that are 6 feet in length. Do not use additional wire to increase this distance. It is recommended that the battery be in its own box and at least 2 feet from the SF 709 in a space that has some ventilation.
- e) **Cool** - Room air temperature should be between 30 and 105 degrees F. (0 to 40 degrees Centigrade).

Caution! Do not block or obstruct either the fan or the exit air ports of the unit. Do not place objects on top or against the unit. Overheating and damage to the unit may result.

Warning! The SF 709 has several components with electrical contacts that switch electrical currents. Opening or closing any of these electrical contacts can produce a spark that could ignite an explosive air mixture. To prevent fire or explosion, do not install the SF 709 in a compartment that contains a flammable liquid such as gasoline or in the same box as a battery - which under some conditions can emit small quantities of hydrogen gas.

4 Battery Considerations

4.1 Battery Selection

Given a fixed output power requirement, the operating time that the *SF 709* will provide in the absence of electricity, is determined only by the size and condition of the battery. **It is important for the user to select a deep cycle, sealed, and maintenance free type, such as a marine battery. Automotive batteries are not recommended.**

4.2 Battery Condition

The condition of a battery is determined by its ability to attain and maintain a 100% state of charge. In order to measure the state of charge the user should use a digital voltmeter that can display hundredths of a volt when measuring 12 Volts. The user should measure battery voltage at the battery posts, with the battery completely disconnected. For deep cycle batteries, the following table relates the State of Charge to Battery Voltage.

State of Charge	Battery Voltage
100%	12.7-12.9
80%	12.5-12.6
60%	12.3-12.4
40%	12.1-12.2
20%	11.9-12.0

4.3 Determining the Operating Time with a New Battery

$$T = \frac{(A-Hr) \times 10}{W}$$

where
T = time (in hours)
A-Hr = Ampere-Hour rating of the battery
W = Continuous Watts drawn by the Appliance (Load)

e.g. A 100 Ahr. battery used to supply a 400 Watt continuous load will last for 2.5 hours. In most applications, however, the draw is not continuous and is usually less than a 50% duty cycle. This has the effect of doubling the time to discharge.

Batteries can also be used in multiples and connected in banks to increase operating time. In the case of a battery bank, the (A-Hr) inserted in the above equation should be the total Ampere Hours of all the batteries in the bank. These batteries should be connected in parallel. (All plus terminals together, and all minus terminals together.)

5 Installation Test

Energize the stove. After allowing it about 15 minutes to heat up, extract the SF 709's main power cord from the AC wall receptacle to simulate power failure. The appliance (load) should continue to operate normally or in the case of certain appliances reinitiate the start up cycle.

The SF 709 puts out sine wave power. Simply stated, it is a form of power that is of the same quality as power sold by utility companies. Therefore there is no discernible difference in the operating characteristics of appliances when operated by the SF 709 versus being plugged directly into the utility.

Plug the AC power cord back into the wall outlet (or turn switch controlling wall outlet back to "on" if it has been turned off instead of pulling the plug above). The appliance should continue to operate. It is now out of the "battery back up" mode and has returned to its normal state of charging the battery.

Once properly connected, the SF 709 system requires no maintenance. When AC power disappears, it will automatically convert battery power to AC power for appliance operation. It will automatically replenish the battery when AC power returns. During all of these times and power transitions, the SF 709 leaves the supply of power to the heating appliance completely uninterrupted and requiring no manual adjustments.

6 Trouble Shooting Guide

Symptom - Unit is connected and energized but will not put out power when utility power is present.

Suspected Causes -

A) The top fuse on the front panel is open. Fuses should be checked with continuity testers. Visual indications are not always accurate.

Symptom - Unit is connected and energized but will not supply inverter (stand by) power when utility power is removed. The inverter "Power" light is "OFF".

Suspected Causes -

- A) Battery is spent or defective
- B) Battery connections are faulty

Symptom - Unit is connected and energized but will not supply inverter (stand by) power when utility power is removed. The inverter "Power" light is "ON".

Suspected Causes -

- A) One of the fuses on the front panel is open. Fuses should be checked with continuity testers. Visual indications are not always accurate.
- B) The short power cord on the front panel is disconnected from the inverter.

Symptom - Unit is connected and energized but will not supply inverter (stand by) power when utility power is removed. The inverter "Power" light is "ON". Inverter alarm is sounding.

Suspected Causes -

- A) The battery voltage is below 11 VDC. The battery is discharged and needs to be recharged or replaced.

Symptom - Battery will not recharge.

Suspected Causes -

- A) One of the fuses on the front panel is open. Fuses should be checked with continuity testers.
- B) Battery is old or defective.

Symptom - Unit works on back up power only and will not switch to utility power AC even when AC is present at the system power cord (the black cord in Figure #2)

- A) One of the fuses on the front panel is open. Fuses should be checked with continuity testers.

7 Warranty and Repair

Should your investigations indicate that your new SF 709 is defective or damaged and your unit is still under warranty then follow the steps on the warranty card.

If the warranty period has expired or if the warranty has been violated due to operator error or misuse, then call :

SEC America, LLC, Repair Department, at 802-**865-8388** or fax SEC America, LLC at 802-865-8389 to receive authorization for shipment back to factory for a survey and possible repair.

Warranty

The SF 709 Heater Sentry comes with a 1 year warranty covering parts and labor. The warranty is described in the warranty card in the owner's manual of this unit.

LIMITED WARRANTY

We warrant each instrument, sold by us, or our authorized agents, to be free from defects in material and workmanship and that it will perform within applicable specifications for a period of one year after original shipment. Our obligation under this guarantee is limited to repairing or replacing any instrument or any part thereof, except fuses and pilot lights, which shall within one year after delivery to the original purchaser, be returned to us with transportation charges prepaid, prove after our examination to be thus defective.

The above limited warranties take the place of all other warranties, expressed or implied, and correction of such defects by replacement or repair shall constitute a fulfillment of all obligations under the terms of the warranties. The warranties do not cover any unit that has been damaged either in transit or by misuse, accident or negligence. No warranty or representation by anyone other than this Company shall be binding on us.

To return a unit send only to the following address:

SEC America, LLC
81 Ethan Allen Drive
S. Burlington, VT 05403

**PLEASE RETAIN YOUR ORIGINAL BILL OF SALE. IT MUST
BE SUBMITTED WHEN MAKING ANY WARRANTY CLAIM**