



Model 443 PS Pump Sentry
Owner's Manual

October 27, 2021

Index

	Page
Quick Installation & Battery Essentials.....	3
Precautions and Sequencing During Initial Hookup....	4
How Pump Sentry Works.....	5
Important Safety Instructions.....	6
Safety Warnings.....	7
Battery Precautions.....	8
Battery Box.....	10
Installation Location.....	10
Making Connections.....	11
Installation Test.....	11
Changing the Battery.....	12
Charger Functions.....	13
Uninterruptible Power Indicator	13
Fan Operation	13
How to Discern when Pump Sentry is Operational in Back Up Mode	15
How to Discern when Pump Sentry is Operational in Standby Mode	15
Fuses	15
Audible Alarm	15
Warranty.....	16

Pump Sentry™

Model 443PS

INSTALLATION INSTRUCTIONS

QUICK INSTALLATION & BATTERY ESSENTIALS

443PS Pump Sentry™ is designed to operate with a pump whose electrical current draw does not exceed 5A and an external battery or battery bank whose nominal operating voltage is 12V. The single or combined A-Hr. rating of the batteries should **not exceed 250 A-hr.** A full recharge will take 13 hours or 30 hours for batteries of 100 A-hr. and 250 A-hr. respectively. Pump Sentry™ will maintain batteries at full charge while electricity is available. See page 13 of this manual to learn more about the charger function indicators.

BATTERY TYPE

Only batteries conforming to Battery Council International (BCI) group size 27 or larger are recommended. Only deep cycle batteries are designed for the type of service which Pump Sentry™ requires. **INSTALL ONLY deep cycle batteries.** (wet cell or AGM type) The marine-variety is acceptable. **DO NOT use car batteries.**

BATTERY BOX

Your selected battery(ies) should be installed in a high quality plastic or metal battery box that comes with a lid that is designed for said box. It is available at the point of battery purchase.

BATTERY CABLES

Use only the cables that are an integral part of 443PS Pump Sentry™. Do not lengthen said cables by any way. Doing so will cause a degradation in the device performance.

The ends of these cables are furnished with Ring terminals designed to fit over the wing nut posts of most batteries.

PRECAUTIONS & SEQUENCING DURING INITIAL HOOKUP

- a) Secure Pump Sentry™ in its designated spot. It is recommended that the unit be placed on a shelf or mounted to a wall.
- b) Make sure the ON/OFF switch is in the OFF position and that the Pump Sentry™ power cord is not plugged into an AC outlet.
- c) Slide the battery into its protective box and place into its designated spot sufficiently close to the Pump Sentry™ to allow the battery cables to reach. **DO NOT USE LONGER CABLES THAN THOSE SUPPLIED WITH PUMP SENTRY™** as this may adversely affect the time available for backup operation.
- d) Connect the ring terminal end of the BLACK battery cable to the battery NEGATIVE terminal.
- e) Connect the ring terminal end of the RED battery battery cable to the battery POSITIVE terminal. **WARNING: WHEN DOING THIS STEP THERE WILL BE A PERCEPTIVE SPARK AT THE TERMINAL AS SOME COMPONENTS IN THE PUMP SENTRY™ CHARGE UP. THIS IS NORMAL.**
- f) Once (e) is completed cover your battery box and secure the lid.
- g) Plug the sump pump into the Pump Sentry™.
- h) Plug the Pump Sentry™ into a wall outlet which has a minimum capacity of 20A.
- i) Turn ON the ON/OFF switch located to the left of the fan air intake port.
- j) Installation is complete.

INSTALLATION TEST

To make sure the installation is good, it should be tested per the following:

- a) Raise the water level float switch controlling the pump causing the pump to go ON.
- b) Disconnect the Pump Sentry's plug, mentioned in (h), from the wall outlet. After a slight pause your sump pump should continue to operate. If it does not, review steps (a) through (i) above.

The Pump Sentry™ is a power station designed to operate your pump during a power outage. When properly installed, it will provide many years of reliable service.

To ensure that the Pump Sentry™ is optimally used and properly connected, we recommend its installation be made by a licensed electrician or fully qualified professional. *Read these instructions completely and follow directions carefully.*

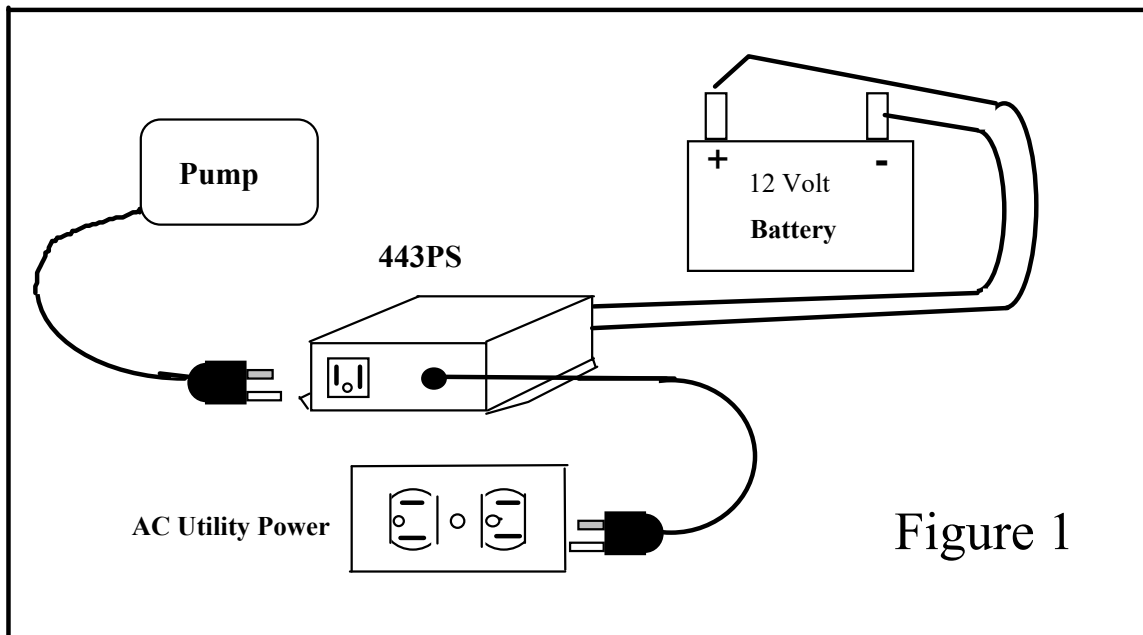

How Pump Sentry Works

When electricity is present, Pump Sentry™ charges a 12-volt battery and surveys the power line. At the instant that a power failure occurs, the Pump Sentry converts the energy stored in the battery to AC power to operate your pump. When AC utility power is restored, the Pump Sentry automatically switches your pump back to AC utility power, recharges the battery, and monitors the power line.

While Pump Sentry is a sophisticated electronic device, it should not be expected to perform beyond its limitations, and extreme care should be taken to insure safe operation within specifications.

IMPORTANT SAFETY INSTRUCTIONS

READ AND SAVE THESE INSTRUCTIONS – THIS MANUAL CONTAINS IMPORTANT INSTRUCTIONS

FAILURE TO FOLLOW SAFETY INSTRUCTIONS AND WARNINGS COULD RESULT IN *INJURY OR DEATH*

- Read all the instructions before installing or operating the Pump Sentry.
- **ALWAYS disconnect batteries and AC power source from the Pump Sentry before storing, handling, or making any adjustments to the unit.**
- Use Pump Sentry only as described in this manual. Any other use not recommended by the manufacturer may cause **fire, electric shock, or injury.**
- **Do Not** sit or stand on the Pump Sentry unit. **Keep children away!**
- **Do Not** place objects on the Pump Sentry unit or allow vents to become blocked.
- **Do Not** smoke, use sparking electrical devices, or allow open flame near the unit while working with it.
- **Do Not** install Pump Sentry in locations classified as hazardous per N.E.C. ANSI/NFPA 70 – 1984.

WARNING: ELECTRICAL SHOCK HAZARD

- This unit has not been evaluated for use outdoors. **Never operate Pump Sentry outdoors.**
- **Never operate** Pump Sentry with battery enclosure open.
- **Never operate** Pump Sentry in a wet location.
- **Never operate** Pump Sentry in a location where liquid or moisture will come in contact with, splash, or drip into unit.
- **Do Not** insert or allow foreign objects to enter any ventilation or exhaust opening as this may cause electrical shock and/or fire hazard.

WARNING:
**RISK OF ELECTRICAL
SHOCK**

In the event of a short circuit, grounding reduces the risk of electrical shock by providing a safe path to ground. The Pump Sentry must be properly grounded.

The Pump Sentry is equipped with a cord having a ground wire with an appropriate three pronged plug. The plug must be used with an outlet that has been installed and grounded in accordance with all local electrical codes and ordinances. Where a two pronged wall outlet is encountered, it must be replaced with a three pronged outlet by a qualified Electrician to reduce the risk of shock, the third prong must not be cut off the plug. *DO NOT attempt to defeat this safety feature.*

Use Pump Sentry only with adequate wiring that is up to electrical code specifications. Connect to properly grounded outlets only.

WARNING:
**RISK OF ELECTRICAL
SHOCK**

The Pump Sentry is capable of, and intended to generate electrical voltage when *unplugged* from a wall outlet or when AC power is shut off.

Because Pump Sentry uses batteries to generate 120 volts of AC power, both the batteries and the power cord must be disconnected to neutralize the Pump Sentry. Failure to disconnect *both* the batteries and the power cord could result in electrical shock sufficient to cause injury or death

**FAILURE TO COMPLY WITH THE ABOVE WARNINGS COULD
RESULT IN INJURY OR DEATH**

BATTERY PRECAUTIONS:

WARNING:
IMPORTANT SAFETY INSTRUCTIONS
SAVE THESE INSTRUCTIONS.

1. Servicing of batteries should be performed or supervised by a person knowledgeable about batteries and the required precautions. Keep unauthorized personnel away from batteries.
2. When replacing batteries, use only models conforming to Battery Council International (BCI) 27 DC specifications for Group 27 Deep Cycle Marine batteries. At the time of this publication, the following model batteries are recommended. At the time of purchase, verify that these models, or any other model, conform to BCI 27DC specifications for Group 27 Deep Cycle Marine Batteries. Below is a partial listing of battery models suitable for Pump Sentry:

<i>Die Hard</i>	<i>Model 27524</i>
<i>Exide</i>	<i>Model NC-27</i>
<i>Interstate</i>	<i>Model SRM-27</i>
<i>Metropolitan</i>	<i>Model 27T-36</i>
<i>NAPA</i>	<i>Model 8270</i>
3. **CAUTION – Do Not** dispose of batteries in a fire. The batteries might explode.
4. **CAUTION – Do Not** open or mutilate the batteries. Released electrolyte is harmful to skin and eyes
5. **CAUTION – A battery can** present a risk of electrical shock and high short circuit current. The following precautions should be observed when working on batteries.
 - A. Remove Watches, Rings, and other Jewelry and metal objects.
 - B. Use tools with insulated handles.
 - C. Do Not lay tools or metal objects on top of batteries.
 - D. Wear safety goggles and a face shield.
5. **CAUTION – The** electrolyte is a diluted sulfuric acid mixture that is Corrosive and harmful to the skin and eyes. It is also electrically conductive. Observe the following rules when working with the electrolyte solution.

- A. Wear full eye protection and clothing.
- B. If electrolyte comes in contact with the skin, wash it off immediately.
- C. If electrolyte comes in contact with the eyes, flush thoroughly with water and seek medical attention immediately.

6. **CAUTION** – Lead acid batteries can present a risk of fire and explosion

because they generate hydrogen gases. The following precautions must be followed.

- A. **Do Not** smoke when near batteries.
- B. **Do Not** cause sparks or allow open flame in the battery area.
- C. **Discharge static electricity** from your body and clothing before touching batteries by first touching a grounded surface.

7. See Battery Manufacturers' installation manual for additional safety and maintenance instructions.

BATTERY BOX

Your selected battery should be stored in a high quality plastic or nylon battery box with a lid that is designed for this purpose.

LOCATION

- In a typical installation, the Pump Sentry should be mounted on the wall, above the sump pit or crock, and in accordance with all applicable local electrical codes.
- It should be in close proximity to a grounded AC

outlet and the battery box (not closer than 2 feet).

VENTILATION

- **Do Not** block either the fan or the exit air ports of the Pump Sentry. Allow at least 2 inches of air clearance on all sides. Any room in which the Pump Sentry is mounted should have adequate ventilation.

UNDER NO CIRCUMSTANCES

Should the Pump Sentry be mounted in a confined area or in a sump pump pit or crock.

WARNING! The Pump Sentry has several components with electrical contacts that switch electrical currents. Opening or closing any of these electrical contacts can produce a spark that could ignite an explosive air mixture. To prevent fire or explosion, do not install the Pump Sentry in any area which might contain flammable liquids or gases. Do not install Pump Sentry in the same confined area as the battery box.

- Pump Sentry is not only an electrical appliance, but also produces a potentially dangerous and hazardous electrical current even when a power outage occurs. It is safe when installed and used properly. **Keep children away.**

MAKING CONNECTIONS

After mounting Pump Sentry to the wall, follow these steps.

- Make sure the ON/OFF switch is in the OFF position.
- Connect the red battery cable of the 443PS to the Red (Positive) + terminal of the Battery.
- Connect the black battery cable of the 443PS to the Black (Negative) – terminal of the Battery.

WARNING! DO NOT REVERSE THESE CONNECTIONS. DAMAGE TO THE PUMP SENTRY WILL OCCUR AND YOU WILL VOID THE WARRANTY.

WARNING! A spark may occur when connecting the second cable. This is normal. An explosion hazard may exist if flammable liquid or gas is present. INSTALL AND OPERATE PUMP SENTRY IN A WELL VENTILATED AREA ONLY.

- Plug your pump into the Pump Sentry's AC outlet.

- Plug the Pump Sentry into a 120 volt AC outlet.
- Turn ON/OFF switch to the ON position.

INSTALLATION TEST

- After making the connections as instructed above, cycle the pump to ensure its operation under normal conditions.
- Remove power cord from the AC wall outlet to simulate a power failure. The fan will not necessarily be activated. It is thermostat controlled and will turn only when the temperature of the wall of the stove sentry exceeds 50C (122F).
- Cycle the pump to ensure operation in “battery back up” mode.
- Plug the Pump Sentry AC power cord back into the wall outlet. Cycle the pump. Note that after 2 seconds the “charging”/”charged” LED of the Battery Monitor has lit or flashing. This is normal and is an indication that the Pump Sentry has recognized the return of normal AC power. The Pump Sentry is no longer in “battery back up” mode and has returned to its normal

state of charging the battery and providing line power.

CHANGING THE BATTERY

If for any reason the battery needs changing, it is important to *follow the steps below, in the order shown* to avoid damage to the Pump Sentry unit.

1. Turn the ON/OFF switch on the Pump Sentry to the OFF position.
2. Unplug the input power cord of the Pump Sentry from the AC outlet.
3. Unplug the input power cord of the pump from the AC outlet on the Pump Sentry
4. Disconnect the 443PS cables from the battery.

CAUTION: MAKE SURE THAT THE PUMP SENTRY IS DISCONNECTED FROM AC POWER BEFORE DISCONNECTING BATTERY CABLES.

5. Replace the battery.
6. Reconnect the Pump Sentry following the steps under the heading **MAKING CONNECTIONS.**

MAINTENANCE

Once properly connected, the Pump Sentry requires no

maintenance. When AC power fails, it will automatically convert battery power to AC power for operation of the pump. It will automatically recharge the battery when AC power returns. During all of these times and power transitions, the Pump Sentry requires no manual adjustments.

SPECIFICATIONS ARE SUBJECT TO CHANGE WITHOUT NOTICE.

Charger Functions

The smart charging system in Pump Sentry 443PS is microprocessor controlled to yield optimum charging rates and long battery life.

When the electrical source is restored allowing the resumption of the charging process, there is a 2 second delay during which the charge state of the battery is assessed. After this delay, The bottom of the two LED indicators comprising the battery monitor will illuminate. These LEDs inform the user regarding the state of the battery:

LED	State of Battery
Bottom LED “Flashing” -	The battery is in the process of recharging.
Bottom LED “On” -	The battery is fully charged.
Replace Battery LED -	When batteries age to the point where they can maintain their fully charged state only for short periods of time, it is an indication that their capacity has decreased. They no longer have the ability to sustain their loads as they did when they were new. The Pump Sentry detects this degradation causing the Replace Battery LED to illuminate. When the battery reaches below 50% of its new battery state, this condition is detected by the monitor. Other LED’s may be lit at the same time.

Figure #1 on page 14 shows the Battery Monitor LED array.

Uninterruptible Power Indicator

The “Power Output” indicator shown in Figure #1 informs the user that AC power is present at the output receptacle providing power to the load. This LED is applicable to both the standby (AC line power present) and Back Up (Battery Power) states.

This LED will be extinguished in the following situations:

- a) The main fuse is blown (in the Standby or Back Up states). See Section on Fuses (Page 12)
- b) The battery is exhausted (in the Standby state)

Figure #1 on page 14 shows the location of this Uninterruptible Power Indicator.

Fan Operation

The air-intake fan, located adjacent to the red DC cable terminal, is thermostat controlled. It operates only when the internal surface of the Pump Sentry exceeds 122F. This eliminates unnecessary fan operation thereby minimizing battery loading.

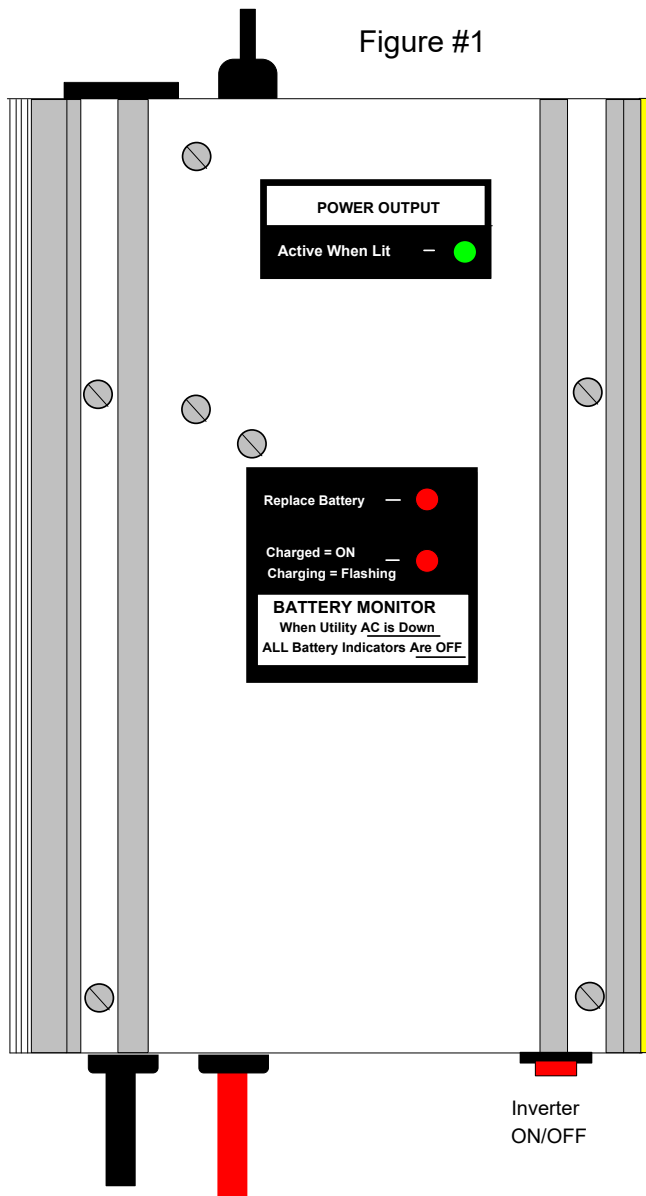

TOP VIEW

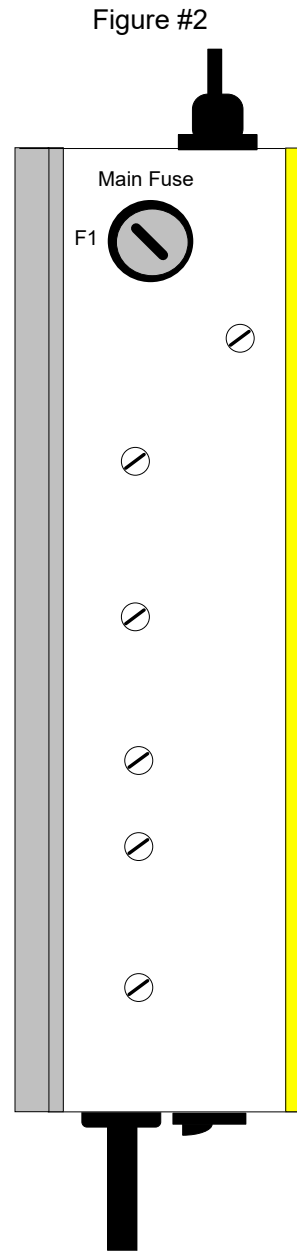

SIDE VIEW

How to Discern When Pump Sentry is Operational in the Backup Mode

When all LED's of the battery monitor are OFF, and the pump sentry is plugged into an AC outlet, the unit is in the back up mode. In this mode when there is sufficient energy in the battery to operate the system, the uninterruptible power LED is illuminated. Once the battery is depleted the uninterruptible power light will extinguish, indicating an absence of AC power at the Pump Sentry's output.

How to Discern When Pump Sentry is Operational in the Standby (Line Power) Mode

When at least one of the Battery Monitor LED's in ON, and the pump sentry is plugged into an AC outlet, the unit is in standby mode. In this mode, the uninterruptible power LED remains illuminated.

Fuses

Figure #2 on page 14 shows the location of a protective fuse F1.

F1, provides secondary protection against severe overload. When this fuse is blown, 120 VAC to the output receptacle of the pump sentry is cut off. In this state, the Uninterruptible Power LED will be OFF. Replace the fuse only with the type indicated on the fuse rating label of your unit which can be found next to the fuse holder on the flat side of the unit to the left of the line cord.

Audible Alarm

While operating on Battery Backup Power, when the battery is depleted to the point where it dips below 10.8V, a high pitched audible alarm is emanated from the Pump Sentry. This is a sign, to the user, that he will imminently loose battery power. If the maintenance of battery power is crucial, the user may substitute the spent battery for a fully charged one, by carefully following the directions in the section "Changing the Battery" on page 12.

If the audible alarm is found to be irritable, it may be turned off by simply turning off the ON/OFF switch of the pump sentry. IT IS IMPORTANT TO TURN THIS SWITCH BACK "ON" WHEN THE UNIT'S OPERATION IS REINSTATED. This should take place when utility power comes back on or after the battery has been replaced. FAILURE TO DO THIS WILL LEAVE THE USER WITHOUT BACK UP PROTECTION.

Pump Sentry 443PS

Manufactured by
SEC America Corp.
S. Burlington, VT, 05403

Manufacturers Limited Warranty

Pump Sentry is warranted to be free from defects in material and workmanship and to perform within applicable specifications for a period of two years after original shipment. Obligation under this guarantee is limited to repairing or replacing any part thereof, except fuses and pilot lights, which shall within one year returned to us with transportation charges prepaid, and prove after our examination to be thus defective.

The above limited warranties take the place of all other warranties, expressed or implied and correction of such defects by replacement or repair shall constitute a fulfillment of all obligations under the terms of the warranties. The warranties do not cover any unit, which has been damaged either in transit or by misuse, accident or negligence. No warranty or representation by anyone other than this Company shall be binding on us.

SEC America Corp.
78 Ethan Allen Drive,
S. Burlington, VT 05403

