



Model 933 Sentry / Model 1733 Sentry

Owner's Manual

July 20, 2023

Index

	Page
Quick Installation & Battery Essentials.....	3
Precautions and Sequencing During Initial Hookup....	4
Quick Functional Test.....	5
How the Sentry Works.....	6
Important Safety Instructions.....	6
Safety Warnings.....	7
Battery Precautions.....	8
Battery Box.....	9
Installation Location.....	9
Making Connections.....	10
Installation Test.....	11
Changing the Battery.....	12
Charger Functions.....	13
Uninterruptible Power Indicator	14
Fan Operation	14
How to Discern when Sentry is Operational in Back Up Mode	16
How to Discern when Sentry is Operational in Standby Mode	16
Fuses	16
Audible Alarm	16
Warranty.....	17

Models 933 / Model 1733 SENTRY INSTALLATION INSTRUCTIONS

QUICK INSTALLATION & BATTERY ESSENTIALS

The Sentry is a high quality power station that generates a sine wave output that will handle any type of load within its rating specifications.

The Sentry is designed to operate with an external battery or battery bank whose nominal terminal **voltage is 12V**, and whose single or combined A-Hr. rating does **not exceed 250 A-hr.** The load on the 933 sentry should not exceed **10 amps** running and a **25 amps** startup surge rating. The load on the 1733 sentry should not exceed **15 Amps** running with a **45 amps** startup surge.

A full recharge will take 26 hours to 60 hours for batteries of 100 A-hr. and 250 A-hr. respectively. The sentry will maintain batteries at full charge while electricity is available. See page 11 of this manual to learn more about the charger function indicators.

BATTERY TYPE

Only batteries conforming to Battery Council International (**BCI**) **group size 27 or larger** are recommended (up to size 31). **INSTALL ONLY** deep cycle batteries. (wet cell or AGM type) The marine-variety is acceptable. **DO NOT use car batteries or lithium.**

BATTERY BOX

Your selected battery(ies) should be installed in a high quality plastic or metal battery box that comes with a lid that is designed for said box. It is available at the point of battery purchase.

BATTERY CABLES

Use only the cables furnished with the Sentry that are packaged in its carton. They are equipped with the terminations necessary for reliable and solid connection. The ends with the blade terminals mate with the RED and BLACK battery cable connectors on the Sentry, while the other ends are furnished with ring terminals designed to fit over the wing nut posts of most batteries.

PRECAUTIONS & SEQUENCING DURING INITIAL HOOKUP

- a) Secure the Sentry in its designated spot. It is recommended that the unit be placed on a shelf or mounted to a wall.
- b) Make sure the ON/OFF switch is in the OFF position and that the Sentry power cord is not plugged into an AC outlet.
- c) Connect the blade end of the red battery cable supplied with the unit into the red terminal block located adjacent to the fan air intake port. Tighten the set screw of the block till the cable is well secured.
- d) Perform the sequence in (c) with the black cable into the black terminal block located adjacent to the red one.
- e) Slide the battery into its protective box and place into its designated spot sufficiently close to the Sentry to allow the battery cables to reach. **DO NOT USE LONGER CABLES THAN THOSE SUPPLIED WITH THE SENTRY** as this may adversely affect the time available for backup operation.
- f) Connect the ring terminal end of the **BLACK** battery cable to the battery **NEGATIVE** terminal.
- g) Connect the ring terminal end of the **RED** battery cable to the battery **POSITIVE** terminal. **WARNING: WHEN DOING THIS STEP THERE WILL BE A PERCEPTIVE SPARK AT THE TERMINAL AS SOME COMPONENTS IN THE SENTRY CHARGE UP. THIS IS NORMAL.**
- h) Once (g) is completed cover your battery box and secure the lid.
- i) Plug the appliance into the Sentry.
- j) Plug the Sentry into a wall outlet which has a minimum capacity of 15A.
- k) Turn **ON** the ON/OFF switch located to the left of the fan air intake port. This has been achieved when the bottom of the rocker has been depressed and the top of the rocker reveals a red surface. The ON/OFF switch only disables the battery backup function. The Sentry always allows power from your power outlet to your appliance regardless of the switch position. Therefore upon installation completion, ensure the switch is **ON** or else there will be no backup function. The switch is **ON** when the red portion of its rocker is visible.
- l) Installation is complete.

QUICK FUNCTIONAL TEST

To make sure the installation is good; it should be tested per the following:

- a) Plug a load such as a lamp into the sentry with its switch in the ON position. Also turn ON the switch on the sentry with the top of the rocker showing red. See Figure A.



- b) Disconnect the Sentry's plug, mentioned in (j), from the wall outlet. After a slight pause, your Sentry should continue to operate. If it does not, review steps (a) through (l) on page 4.

Fig. A

The Sentry is an innovative power station designed to provide electricity to an appliance during a power outage. When properly installed, it will provide many years of reliable service.

To ensure that the Sentry is optimally used and properly connected, we recommend that its installation be made by individuals familiar with this user manual or a licensed electrician. *Read these instructions completely and follow directions carefully.*

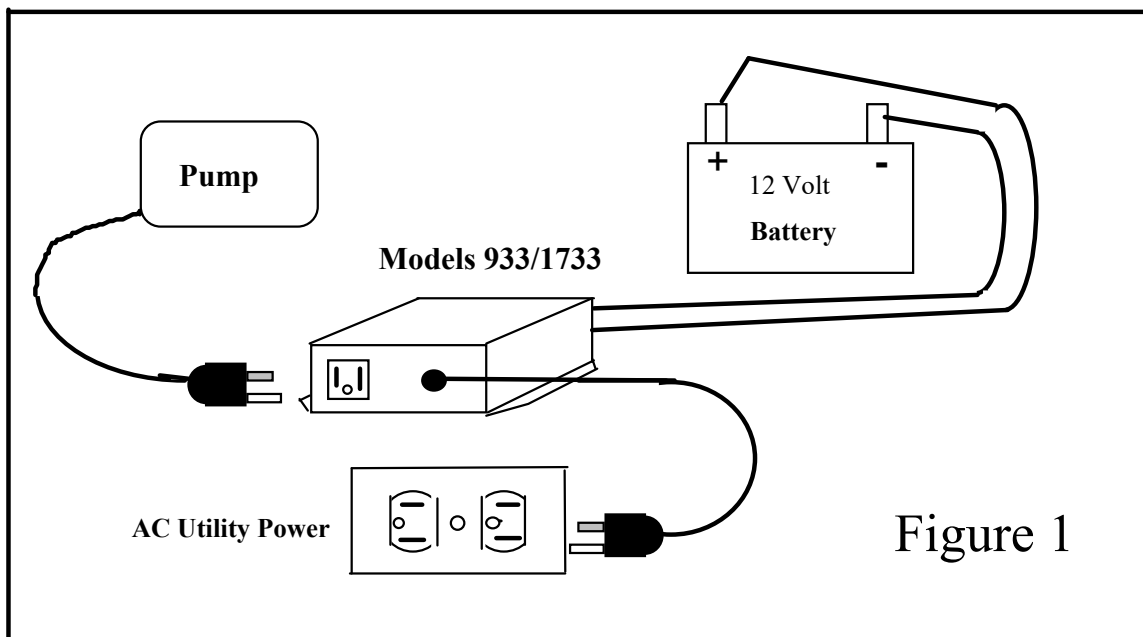

Figure 1

How the Sentry Works

When electricity is present, the Sentry charges a 12-volt battery (bank) and surveys the power line. At the instant that a power failure occurs, the Sentry converts the energy stored in the battery to AC power to operate your appliance. When AC utility power is restored, the Sentry automatically switches your appliance back to AC utility power, recharges the battery, and monitors the power line.

While the Sentry is a sophisticated electronic device, it should not be expected to perform beyond its limitations, and extreme care should be taken to insure safe operation within specifications.

IMPORTANT SAFETY INSTRUCTIONS

READ AND SAVE THESE INSTRUCTIONS – THIS MANUAL CONTAINS IMPORTANT INSTRUCTIONS

FAILURE TO FOLLOW SAFETY INSTRUCTIONS AND WARNINGS COULD RESULT IN *INJURY OR DEATH*

Read all the instructions before installing or operating the Sentry.

ALWAYS disconnect batteries and AC power source from the Sentry before storing, handling, or making any adjustments to the unit.

Use Sentry only as described in this manual. Any other use not recommended by the manufacturer may cause **fire, electric shock, or injury.**

Do Not sit or stand on the Sentry unit. **Keep children away!**

Do Not place objects on the Sentry unit or allow vents to become blocked.

Do Not smoke, use sparking electrical devices, or allow open flame near the unit while working with it.

Do Not install the Sentry in locations classified as hazardous per N.E.C. ANSI/NFPA 70 – 1984.

WARNING:

ELECTRICAL SHOCK HAZARD

This unit has not been evaluated for use outdoors. **Never operate the Sentry outdoors.**

Never operate the Sentry with battery enclosure open.

Never operate the Sentry in a wet location.

Never operate the Sentry in a location where liquid or moisture will come in contact with, splash, or drip into unit.

Do Not insert or allow foreign objects to enter any ventilation or exhaust opening as this may cause electrical shock and/or fire hazard.

WARNING:
RISK OF ELECTRICAL SHOCK

In the event of a short circuit, grounding reduces the risk of electrical shock by providing a safe path to ground. The Sentry must be properly grounded.

The Sentry is equipped with a cord having a ground wire with an appropriate three pronged plug. The plug must be used with an outlet that has been installed and grounded in accordance with all local electrical codes and ordinances. Where a two pronged wall outlet is encountered, it must be replaced with a three pronged outlet by a qualified Electrician to reduce the risk of shock, the third prong must NOT be cut off the plug. *DO NOT attempt to defeat this safety feature.*

Use Sentry only with adequate wiring that is up to electrical code specifications.

Connect to properly grounded outlets only.

WARNING:
RISK OF ELECTRICAL SHOCK

The Sentry is capable of, and intended to generate electrical voltage when *unplugged* from a wall outlet or when AC power is shut off.

Because Sentry uses batteries to generate 120 volts of AC power, both the batteries and the power cord must be disconnected to neutralize the Sentry. *Failure to disconnect **both** the batteries and the power cord could result in electrical shock sufficient to cause injury or death*

**FAILURE TO COMPLY WITH THE ABOVE WARNINGS COULD
RESULT IN INJURY OR DEATH**

BATTERY PRECAUTIONS:

WARNING:

IMPORTANT SAFETY INSTRUCTIONS SAVE THESE INSTRUCTIONS.

1. Servicing of batteries should be performed or supervised by a person knowledgeable about batteries and the required precautions. Keep unauthorized personnel away from batteries.
2. When replacing batteries, use only models conforming to Battery Council International (BCI) specifications for **Group size 27 or larger** Deep Cycle Marine batteries.

Larger BCI group sizes and multiple-battery arrays may also be used to increase backup longevity.

3. **CAUTION – Do Not** dispose of batteries in a fire. The batteries might explode.
4. **CAUTION – Do Not** open or mutilate the batteries. Released electrolyte is harmful to skin and eyes
CAUTION – A battery can present a risk of electrical shock and high short circuit current. The following precautions should be observed when working on batteries.
 - A. Remove Watches, Rings, and other Jewelry and metal objects.
 - B. Use tools with insulated handles.
 - C. Do Not lay tools or metal objects on top of batteries.
 - D. Wear safety goggles and a face shield.

5. **CAUTION –** The electrolyte is a diluted sulfuric acid mixture that is *Corrosive and harmful to the skin and eyes*. It is also electrically conductive. Observe the following rules when working with the electrolyte solution.
 - A. Wear full eye protection and clothing.
 - B. If electrolyte comes in contact with the skin, wash it off immediately.
 - C. If electrolyte comes in contact with the eyes, flush thoroughly with water and seek medical attention immediately.

6. CAUTION – Lead acid batteries can present a risk of fire and explosion because they generate hydrogen gases. The following precautions must be followed.

- A. **Do Not** smoke when near batteries.
- B. **Do Not** cause sparks or allow open flame in the battery area.
- C. **Discharge static electricity** from your body and clothing before touching batteries by first touching a grounded surface.

7. See Battery Manufacturers' installation manual for additional safety and maintenance instructions.

BATTERY BOX

Your selected battery should be stored in a high quality plastic or nylon battery box with a lid that is designed for this purpose.

LOCATION

- In a typical installation, the Sentry should be mounted on the wall, above the sump pit or crock, and in accordance with all applicable local electrical codes.
- It should be in close proximity to a grounded AC outlet and the battery box (not closer than 2 feet).

VENTILATION

- **Do Not** block either the fan or the exit air ports of the Sentry. Allow at least 2 inches of air clearance on all sides. Any room in which the Sentry is mounted should have adequate ventilation.

WARNING! The Sentry has several components with electrical contacts that switch electrical currents. Opening or closing any of these electrical contacts can produce a spark that could ignite an explosive air mixture. To prevent fire or explosion, do not install the Sentry in any area which might contain flammable liquids or gases. Do not install Sentry in the same confined area as the battery box.

UNDER NO CIRCUMSTANCES

Should the Sentry be mounted in a confined space.

- Sentry is not only an electrical appliance, but also produces a potentially dangerous and hazardous electrical current even during a power outage. It is safe when installed and used properly.
- **Keep children away.**

MAKING CONNECTIONS

After mounting Sentry to the wall, follow these steps.

- Make sure the ON/OFF switch is in the OFF position.
- Connect the red battery cable to the Red (Positive) + terminal of the Sentry.
- Connect the black battery cable to the Black (Negative) – terminal of the Sentry.

WARNING! DO NOT REVERSE THESE CONNECTIONS. DAMAGE TO THE APPLIANCE SENTRY WILL OCCUR AND YOU WILL VOID THE WARRANTY.

WARNING! A spark may occur when connecting the second cable. This is normal. An explosion hazard may exist if flammable liquid or gas is present. INSTALL AND OPERATE SENTRY IN A WELL VENTILATED AREA ONLY.

- Plug your appliance into the Sentry's AC outlet.
- Plug the Sentry into a 120 volt AC outlet.
- Turn ON/OFF switch to the ON position.

INSTALLATION TEST

- After making the connections as instructed above, cycle the appliance to ensure its operation under normal conditions.
- Remove power cord from the AC wall outlet to simulate a power failure. The fan will not necessarily be activated. It is thermostat controlled and will turn only when the temperature of the wall of the sentry exceeds 45C (113F).
- Cycle the appliance to ensure operation in "battery backup" mode.
- Plug the Sentry AC power cord back into the wall outlet. Cycle the appliance. Note that after 2 seconds at least one of the Battery Monitor LEDs has lit. This is normal and is an indication that the Sentry has recognized the return of normal AC power. The Sentry is no longer in "battery backup" mode and has returned to its normal state of charging the battery and providing line power.

CHANGING THE BATTERY

If for any reason the battery needs changing, it is important to follow the steps below, in the order shown to avoid damage to the Sentry unit.

1. Turn the ON/OFF switch on the Sentry to the OFF position.
2. Unplug the input power cord of the Sentry from the AC outlet.
3. Unplug the input power cord of the appliance from the AC outlet on the Sentry.
4. Disconnect the battery cables from the battery. **CAUTION: MAKE SURE THAT THE SENTRY IS DISCONNECTED FROM AC POWER BEFORE DISCONNECTING BATTERY CABLES.**
5. Replace the battery.
6. Reconnect the Sentry following the steps under the heading **MAKING CONNECTIONS.**

MAINTENANCE

Once properly connected, the Sentry requires no maintenance. When AC power fails, it will automatically convert battery power to AC power for operation of the appliance. It will automatically recharge the battery when AC power returns. During all of these times and power transitions, the Sentry requires no manual adjustments.

SPECIFICATIONS ARE SUBJECT TO CHANGE WITHOUT NOTICE.

Charger Functions

The smart charging system in Sentry is microprocessor controlled to yield optimum charging rates and long battery life.

When the electrical source is restored allowing the resumption of the charging process, there is a 2 second delay during which the charge state of the battery is assessed. After this delay, the bottom most of the LED indicators comprising the battery monitor will illuminate. These LEDs inform the user regarding the state of the battery:

LED

Bottom LED “Flashing” -

State of Battery

The battery is in the process of recharging.

Bottom LED “On” -

The battery is fully charged.

Replace Battery LED -

When batteries age to the point where they can maintain their fully charged state only for short periods of time, it is an indication that their capacity has decreased. They no longer have the ability to sustain their loads as they did when they were new. The Sentry detects this degradation causing the Replace Battery LED to illuminate. When the battery reaches below 50% of its new battery state, this condition is detected by the monitor. Other LED’s may be lit at the same time.

Figure #1 on page 15 shows the Battery Monitor LED array.

Uninterruptible Power Indicator

The “Power Output” indicator shown in Figure #1, when lit, informs the user that AC power is present at the output receptacle providing power to the load. This LED function is applicable to both the standby (AC line power present) and Back Up (Battery Power) states to inform the user that the Sentry is outputting power.

This LED will be extinguished in the following situations:

The main fuse is blown (in the Standby or Back Up states).

See Section on Fuses (Page 16)

The battery is exhausted (in the Standby state)

Figure #1 on page 14 shows the location of this Uninterruptible Power Indicator.

Fan Operation

The air-intake fan, located adjacent to the red DC cable terminal, is thermostat controlled. It operates only when the internal surface of the Sentry exceeds 140F. This eliminates unnecessary fan operation thereby minimizing battery loading.

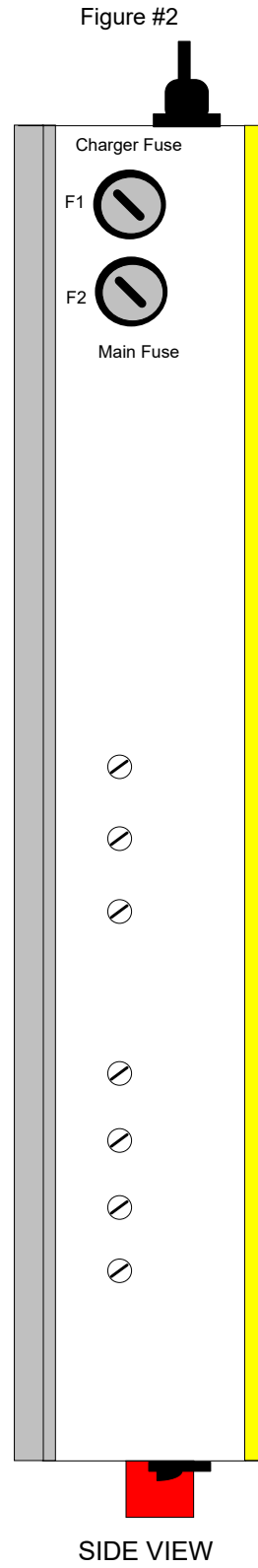
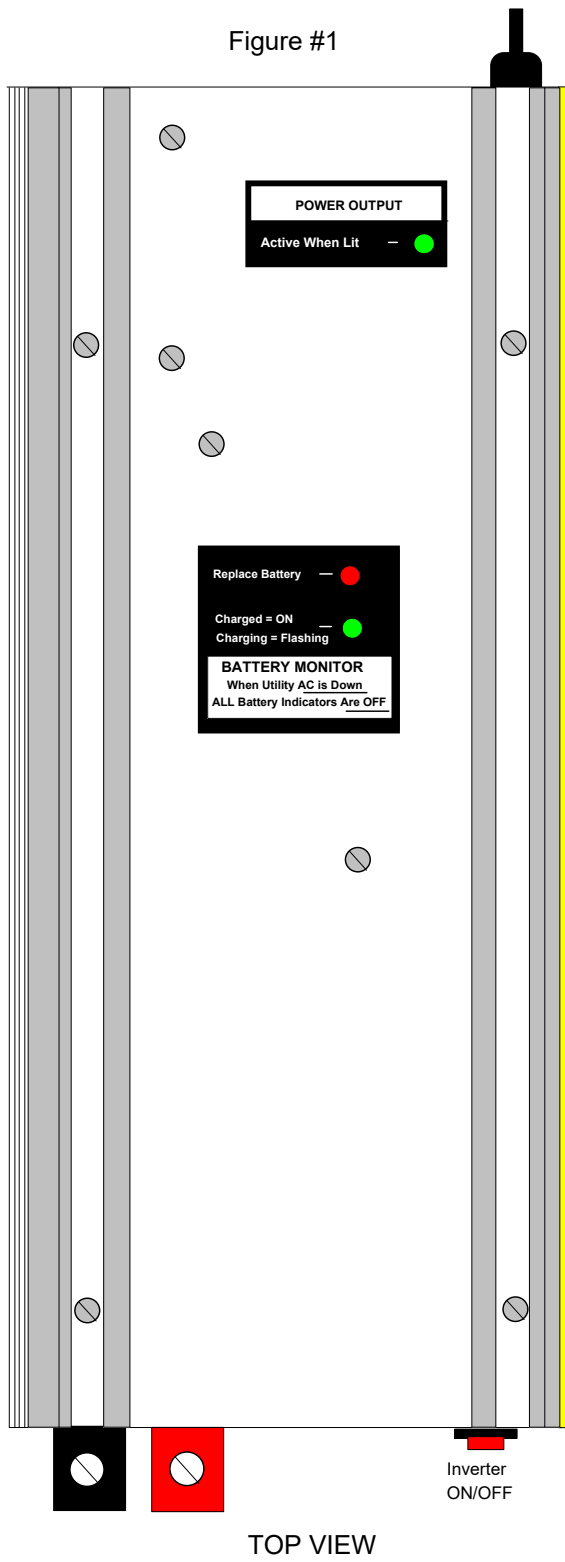

How to Discern When Sentry is Operational in the Backup Mode

When all LED's of the battery monitor are OFF, and the Sentry is plugged into an AC outlet, the unit is in the back up mode. In this mode when there is sufficient energy in the battery to operate the system, the uninterruptible power LED is illuminated. Once the battery is depleted the uninterruptible power light will extinguish, indicating an absence of AC power at the Sentry's output.

How to Discern When Sentry is Operational in the Standby (Line Power) Mode

When at least one of the Battery Monitor LED's in ON and the Sentry is plugged into an AC outlet, the unit is in standby mode. In this mode, the uninterruptible power LED remains illuminated.

Fuses

Figure #2 on page 15 shows the location of two protective fuses F1 and F2 in the 933 sentry. *In the 1733 sentry F2 is found on the rear perforated plate below the "overload" led.*

F1, the charger fuse, provides protection against charger or battery catastrophic failure. When this fuse is blown the Sentry will operate on standby power only until the battery is depleted.

F2, the main fuse, provides secondary protection against severe overload. When this fuse is blown, 120 VAC to the output receptacle of the Sentry is cut off. In this state, the Uninterruptible Power LED will be OFF. Replace fuses only with the types indicated on the fuse rating label of your unit which can be found next to the fuse holders on the flat side of the unit to the left of the line cord.

Audible Alarm

While operating on Battery Backup Power, when the battery is depleted to the point where it dips below 10.8V, a high pitched audible alarm is emanated from the Sentry. This is a sign, to the user, that he will imminently loose battery power. If the maintenance of battery power is crucial, the user may substitute the spent battery for a fully charged one, by carefully following the directions in the section "Changing the Battery" on page 11.

If the audible alarm is found to be irritable, it may be turned off by simply turning off the ON/OFF switch of the Sentry. IT IS IMPORTANT TO TURN THIS SWITCH BACK “ON” WHEN THE UNIT’S OPERATION IS REINSTATED. This should take place when utility power comes back on or after the battery has been replaced. FAILURE TO DO THIS WILL LEAVE THE USER WITHOUT BACK UP PROTECTION.

Sentry Model 933, Model 1733

Manufactured by
SEC America Corp.
S. Burlington, VT, 05403

Manufacturers Limited Warranty

Sentry is warranted to be free from defects in material and workmanship and to perform within applicable specifications for a period of two years after original shipment. Obligation under this guarantee is limited to repairing or replacing any part thereof, except fuses and pilot lights, which shall within one year returned to us with transportation charges prepaid, and prove after our examination to be thus defective.

The above limited warranties take the place of all other warranties, expressed or implied and correction of such defects by replacement or repair shall constitute a fulfillment of all obligations under the terms of the warranties. The warranties do not cover any unit, which has been damaged either in transit or by misuse, accident or negligence. No warranty or representation by anyone other than this Company shall be binding on us.

SEC America Corp.
78 Ethan Allen Drive,
S. Burlington, VT 05403