



**SECAMERICA.COM**

Model 679 CE, DC-DC Converter  
Owner's Manual

**April 22, 2018**

## TABLE OF CONTENTS

	<b>page</b>
<b>I Introduction</b>	<b>1</b>
<b>II Installation</b>	<b>1</b>
2.1 Mounting	1
2.2 Connections	1
2.3 Methods of Converter Activation	2
<b>III Internal Adjustments</b>	<b>3</b>
3.1 Voltage Adjustment	3
3.2 Low Voltage Cutout	4
<b>IV Warranty</b>	<b>5,6</b>
<b>V Mechanical Drawing of Base Plate</b>	<b>7</b>
<b>VI Electrical Specifications</b>	<b>8</b>

# I Introduction

Model 679CE is shipped in fully assembled form. After removing the unit from its packaging and ensuring that it has suffered no damage in shipment, it is important to read this manual and follow its instructions to ensure proper connection and mounting.

Model 679CE is a high power 12 Volt to 16 Volt DC-DC booster converter capable of delivering 80A to its load. It is designed for use with communications equipment for mounting in vehicles of all types and is capable of enduring harsh vibration and shock conditions

# II Installation

## 2.1 Mounting

Model 679CE has an overall length of 13.8 inches with mounting flanges included in this dimension. Hole mounting centers are 13.3 x 3.93 (inches)

## 2.2 Connections

**Tools Required - 1 flat blade screw driver (1/4 in. wide)**

Figure 1 shows the connection panel view of the 679CE.

- The 679 CE, DC-DC Converter can be activated by:**
- 1) Connecting Terminals 1 & 2 on TBA (as factory supplied)
- OR**
- 2) By disconnecting Terminal 1 from Terminal 2 on TBA and connecting terminal 1 to 12 VDC through an ignition switch

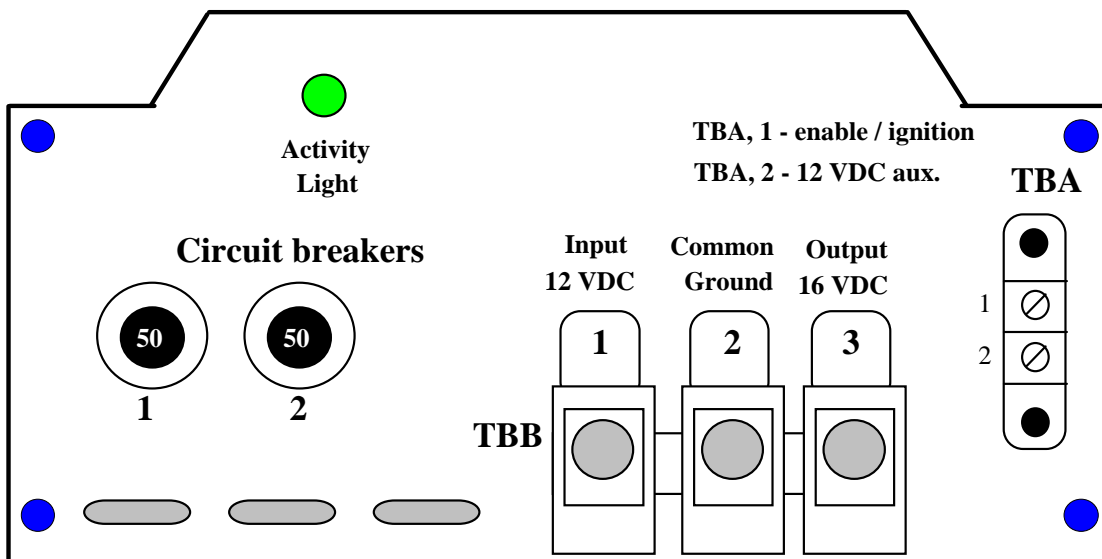

**Figure 1**

### **Prior to Main Input Power Connections:**

The unit comes supplied with qty. (4) KS-35 pin terminals which are designed to interface with the I/O block on the unit. These terminals will accept wire up to #2 gauge in size. They should be used in order to achieve reliable connection.

**Prior to hook up to the vehicular power source, the buttons on the two circuit breakers shown in Figure 1 should be pulled out into the disconnect position. This position is indicated by the exposure of the white portion of the breaker button shaft.** This ensures that there is no sparking from the source of power and also allows a reprieve in case there is a hook up error. (User should carefully review connections as such an error would have to be detected prior to energizing the unit).

Once the breaker buttons are pulled, proceed to make connections as follows:

- A) Connect input +12V line to position #1 of TBB.
- B) Connect input 12V ground to position #2 of TBB.
- C) Connect output +16 V line to position #3 of TBB.
- D) Connect output 16 V ground to position #2 either at the Terminal block or other convenient junction.

Prior to depressing the circuit breaker buttons, installer should:

- 1) Ensure that hook up in steps A through D is correct.
- 2) Select the suitable method of converter activation.

### **2.3 Methods of Converter Activation**

- A) Connect terminal #1 to terminal #2 on terminal block TBA. The 679CE is so configured when shipped from the factory. This configuration allows for converter activation by turning the source power ON and OFF.
- B) The converter can be switched from the vehicle's ignition system. For this method, remove the shorting jumper between terminals #1 and #2 on TBA and connect terminal 1 to the ignition switch or other switch that can enable terminal 1 to access 12 VDC.
- C) Terminal #1 can be connected to terminal #2 through a remote ON/OFF switch and thereby activating the converter.

### III Internal Adjustments

Varying the adjustments of the Model 679CE require the technician to have a stable DC power supply variable from at least 10 VDC to 15 VDC.

To access adjustments turn the unit upside down and remove the base plate by unscrewing the 4 securing screws in its corners. (See drawing 63-1448, p 6).

Orient the converter upside down and horizontally with the connection panel to the left as shown in figure #2.

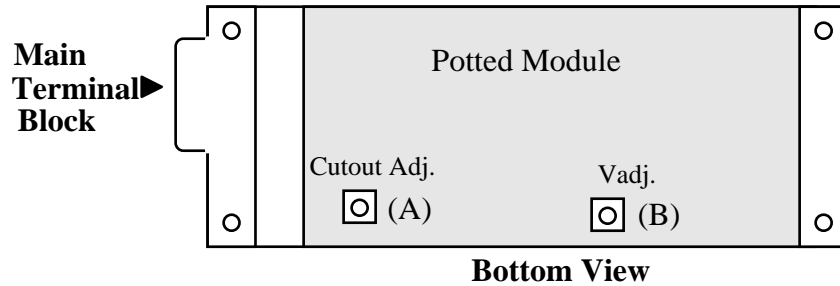

Two potentiometers (A) and (B) can be noticed.

Potentiometer (A) is used to adjust the converter's low voltage cutout point. This point corresponds to the minimum input voltage necessary to keep the converter "ON" (maintaining approximately 26V at the output).

When the converter is in the "OFF" state, the output voltage approximately equals the input voltage. Potentiometer (B) is used to adjust output voltage.

#### 3.1) Voltage Adjustment

a) Hook up the unit to be adjusted as shown in Figure #3 under no load conditions:

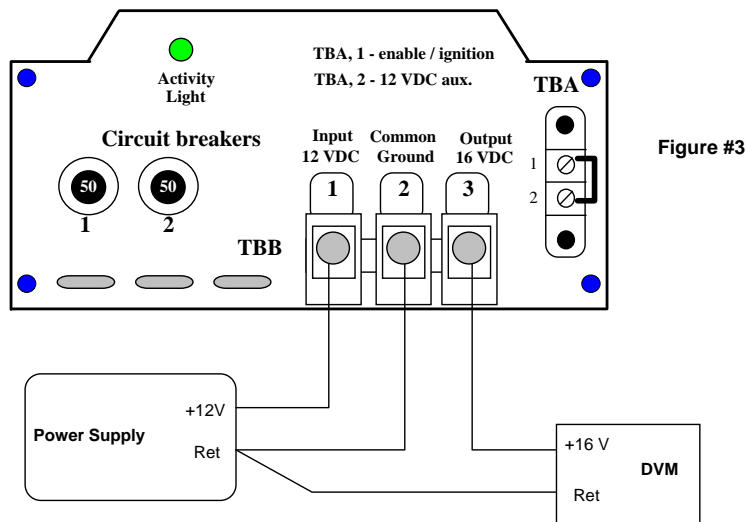

b) Make sure terminals 1 & 2 on TBA are shorted and that the Power supply is turned off. Set the Digital Volt Meter to the appropriate scale to read 16 VDC to two decimals.

c) Energize power supply and adjust its output voltage to +12 VDC. Adjust Potentiometer (B) to the desired setting (between 15.5 VDC and 18 VDC) and observe converter voltage output reading on DVM

d) Turn off power supply.

### 3.2) Low Input Voltage Cutout Adjustment

The Model 679CE is provided with a circuit to protect against destructively deep battery discharges, or discharges beyond the point where the vehicle battery can no longer support ignition.

679CE's are adjusted at the factory to the minimum low input voltage cutout (LIVC) of 10.8 V below which the converter remains inactive. The low input voltage cutout (LIVC) may be readjusted to another level using the test circuit in Figure #4. The LIVC functions such that when the vehicle voltage is drawn below the LIVC, the converter shuts off and becomes dormant as the activity light extinguishes. In this state the converter will feed its input voltage to its output. When in this state, in the event that a voltage equal to or higher than the converter input should be superimposed on the output (e.g. an 18V battery bank) the output configuration of the converter will prevent current from back feeding by presenting an extremely high output impedance. An audible click can be heard and the activity light extinguishes as the LIVC circuit turns off the converter. Its output voltage can be measured to drop from its normal output voltage setting to approximately the source input voltage. The range of LIVC adjustment is 10.8 to 13.0 VDC.

The LVC adjustment set up is as shown in Figure #4.

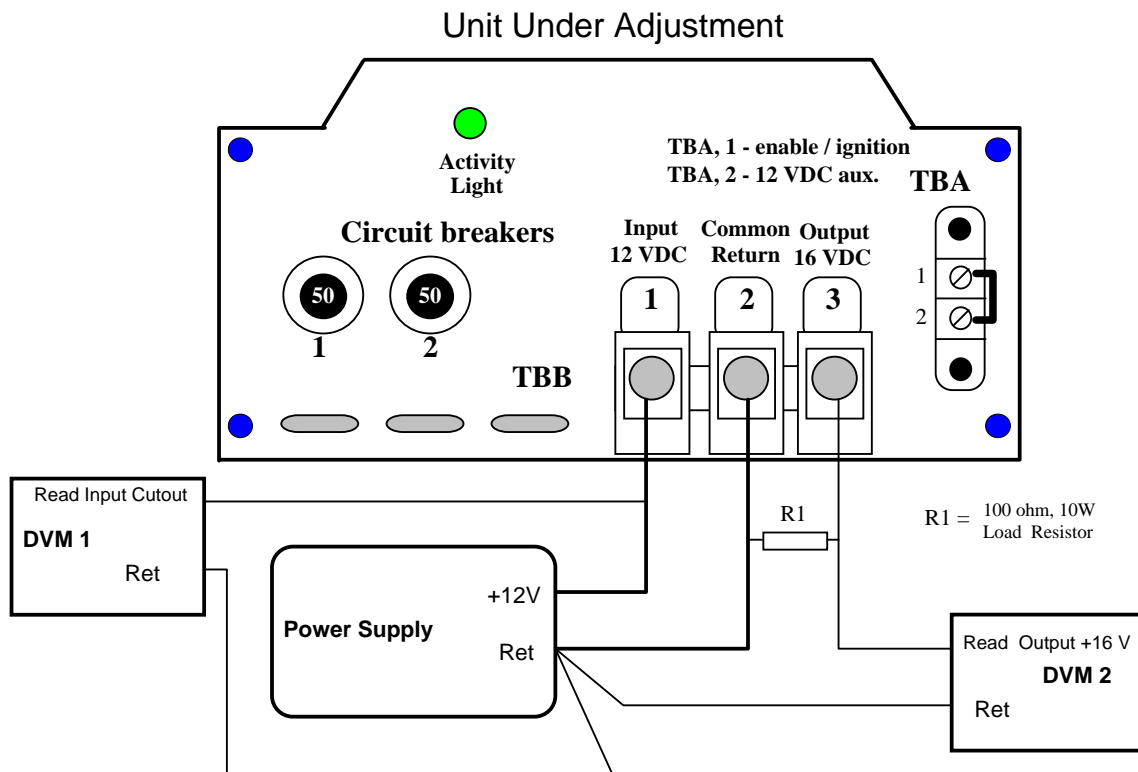

Figure #4

- Turn pot (A) completely clock wise
- Activate converter by turning on the power supply and setting it to the desired cutout voltage
- Very gradually turn pot (A) counter clockwise until simultaneously a click can be heard and the activity light extinguishes accompanied by a drop in the reading on the DVM 2.
- Adjustment is over.

There is approximately 0.8 Volt of Hysteresis between the cutout and turn on voltages of Model 679CE. e.g. if 11 VDC is selected for cutout, that unit will turn back on when an input of at least 11.8 Volts is reapplied. This design serves to prevent rapid fluttering as battery voltage recovers with load removal.

## IV Warranty and Repair

Should your investigations indicate that your new Model 679CE is defective or damaged and your unit is still under warranty then contact SEC America, LLC at 802-865-8388 and obtain return merchandise authorization for credit or exchange.

If the warranty period has expired or if the warranty has been violated due to operator error or misuse, then call :

SEC America Corp., Repair Department, at **802-865-8388** or fax SEC America Corp. at 802-865-8389 to receive authorization for shipment back to factory for a survey and possible repair.

### Warranty

**The Model 679CE has a 1 year warranty covering parts and labor. The warranty is found below:**

#### LIMITED WARRANTY

We warrant each instrument, sold by us, or our authorized agents, to be free from defects in material and workmanship and that it will perform within applicable specifications for a period of one year after original shipment. Our obligation under this guarantee is limited to repairing or replacing any instrument or any part thereof, except fuses and pilot lights, which shall within one year after delivery to the original purchaser, be returned to us with transportation charges prepaid, prove after our examination to be thus defective.

The above limited warranties take the place of all other warranties, expressed or implied, and correction of such defects by replacement or repair shall constitute a fulfillment of all obligations under the terms of the warranties. The warranties do not cover any unit that has been damaged either in transit or by misuse, accident or negligence. No warranty or representation by anyone other than this Company shall be binding on us.

To return a unit send only to the following address:

**SEC America Corp.  
78 Ethan Allen Drive  
S. Burlington, VT 05403**

**PLEASE RETAIN YOUR ORIGINAL BILL OF SALE. IT MUST  
BE SUBMITTED WHEN MAKING ANY WARRANTY CLAIM**

# V Base Plate Mechanical Drawing

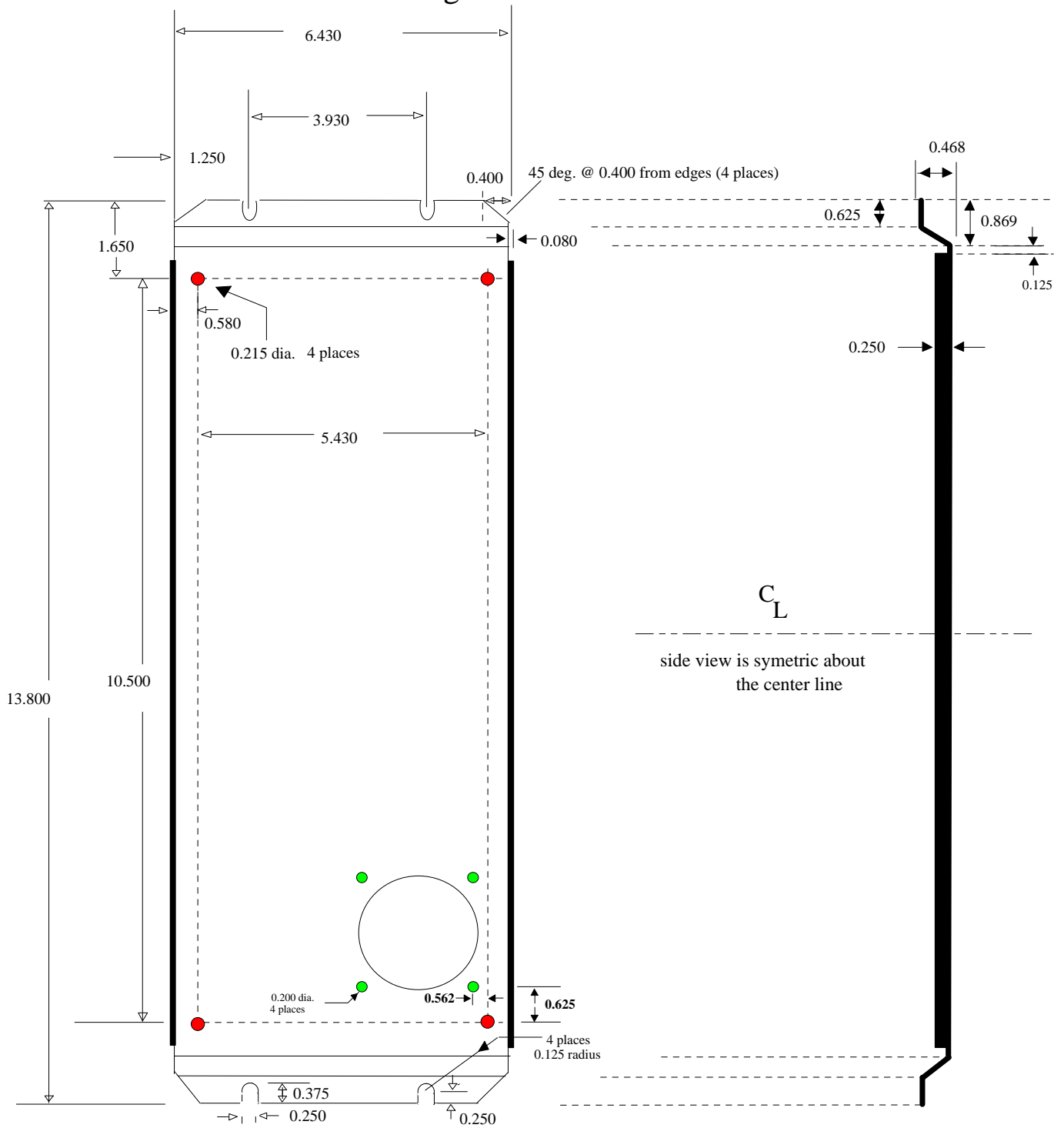

SEC America, LLC S. Burlington, VT 05407	DWG. NO. 63-1448	REV	
		C	



## VI Electrical Specifications:

Output Voltage: 16.0 Nominal (Internally adjustable +/- 0.5V)  
Output Voltage Adjust Range 15.0 VDC to 18.0 VDC (internally adjustable)  
Continuous Max Load Amps: 80 ADC @ 40C ambient (Input 12.5 Vdc)  
70 ADC @ 60C ambient

Maximum Power Dissipation: 70 Watts @ Full Load  
Maximum Input Current: 120 A (12 VDC in)  
Overload Protection: Electronically current limited (primary protection)  
Circuit Breakers at the Input (secondary protection)  
Cooling: Convection or Forced Air  
Thermostat Controlled Fan

Output Ripple Voltage: 10 mV RMS (20C to 75C)  
50 mV RMS (-30C)  
Input Voltage Range: 11 VDC to 15 VDC  
Input Output Isolation: Input and Output returns (Ground) are Common

### Low Voltage Cutout Circuit:

Low Voltage cutout point: Adjustable from 10.5 VDC to 13 VDC  
(internally adjustable)  
factory set for 10.5  
Low Voltage cutout Hysteresis: 1.2 VDC @ 13.0 V / 0.9 VDC @ 10.5 VDC

### Activation Circuits:

- 1) The unit may be activated through the command terminal #1 of terminal block TBA which when connected to +12 VDC of the vehicle will turn on the converter.
- 2) By turning the power source ON or OFF.

Ambient Operating Temperature: -30C to + 60C  
Maximum Humidity: 100% non condensing  
Maximum Elevation: 15000 ft. above sea level

### Mechanical Specifications:

Dimensions: 13.7 L x 7.0W x 3.5 H (inches overall maximum)  
Shipping Weight: 10 lb.  
Construction: Steel base with Aluminum wrap around (painted)  
Mounting Method: #12 Hardware via front and rear mounting flanges  
Mounting Centers: 13.3 x 3.87 (inches)  
Hook Up: 3 Position Splicer Terminal Blocks