

# Pump Sentry

## Models 812 PS & 1612 PS

### INSTALLATION INSTRUCTIONS

The Pump Sentry is an innovative power station designed to operate your pump during a power outage. When properly installed, it will provide many years of reliable service.

To ensure that the Pump Sentry is optimally used and properly connected, we recommend its installation be made by a licensed electrician or fully qualified professional. *Read these instructions completely and follow directions carefully.*

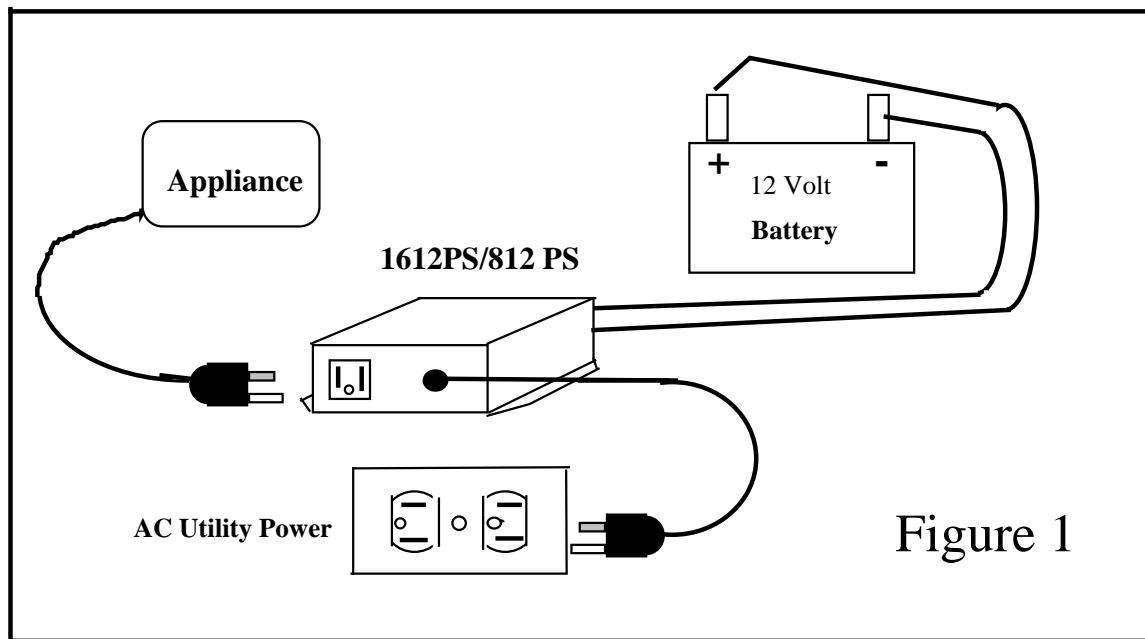

#### How The Pump Sentry Works

When electricity is present, the Pump Sentry charges a 12-volt battery and surveys the power line. At the instant that a power failure occurs, the Pump Sentry converts the energy stored in the battery to AC power to operate your pump. When AC utility power is restored, the Pump Sentry automatically switches your pump back to AC utility power, recharges the battery, and monitors the power line.

While the Pump Sentry is a sophisticated electronic device, it should not be expected to perform beyond its limitations, and extreme care should be taken to insure safe operation within specifications.

## **IMPORTANT SAFETY INSTRUCTIONS**

**READ AND SAVE THESE INSTRUCTIONS – THIS MANUAL CONTAINS IMPORTANT INSTRUCTIONS**

**FAILURE TO FOLLOW SAFETY INSTRUCTIONS AND WARNINGS COULD RESULT IN *INJURY OR DEATH***

- Read all the instructions before installing or operating the Pump Sentry.
- **ALWAYS disconnect batteries and AC power source from the Pump Sentry before storing, handling, or making any adjustments to the unit.**
- Use Pump Sentry only as described in this manual. Any other use not recommended by the manufacturer may cause **fire, electric shock, or injury.**
- **Do Not** sit or stand on the Pump Sentry unit. **Keep children away!**
- **Do Not** place objects on the Pump Sentry unit or allow vents to become blocked.
- **Do Not** smoke, use sparking electrical devices, or allow open flame near the unit while working with it.
- **Do Not** install Pump Sentry in locations classified as hazardous per N.E.C. ANSI/NFPA 70 – 1984.

### **WARNING: ELECTRICAL SHOCK HAZARD**

- This unit has not been evaluated for use outdoors. **Never operate Pump Sentry outdoors.**
- **Never operate** Pump Sentry with battery enclosure open.
- **Never operate** Pump Sentry in a wet location.
- **Never operate** Pump Sentry in a location where liquid or moisture will come in contact with, splash, or drip into unit.

- **Do Not** insert or allow foreign objects to enter any ventilation or exhaust opening as this may cause electrical shock and/or fire hazard.

**WARNING:**  
**RISK OF ELECTRICAL SHOCK**

In the event of a short circuit, grounding reduces the risk of electrical shock by providing a safe path to ground. The Pump Sentry must be properly grounded.

The Pump Sentry is equipped with a cord having a ground wire with an appropriate three pronged plug. The plug must be used with an outlet that has been installed and grounded in accordance with all local electrical codes and ordinances. Where a two pronged wall outlet is encountered, it must be replaced with a three pronged outlet by a qualified Electrician. to reduce the risk of shock, the third prong must not be cut off the plug.

*DO NOT attempt to defeat this safety feature.*

User Pump Sentry only with adequate wiring that is up to electrical code specifications. Connect to properly grounded outlets only.

**WARNING:**  
**RISK OF ELECTRICAL SHOCK**

The Pump Sentry is capable of, and intended to generate electrical current when *unplugged* from a wall outlet or when AC power is shut off.

Because the Pump Sentry uses batteries to generate 120 volts of AC current, both the batteries and the power cord must be disconnected to neutralize the Pump Sentry. *Failure to disconnect both the batteries and the power cord could result in electrical shock sufficient to cause injury or death*

**FAILURE TO COMPLY WITH THE ABOVE WARNINGS COULD RESULT IN INJURY OR DEATH**

## BATTERY PRECAUTIONS:

**WARNING:**  
**IMPORTANT SAFETY INSTRUCTIONS**  
**SAVE THESE INSTRUCTIONS.**

1. Servicing of batteries should be performed or supervised by a person knowledgeable of batteries and the required precautions. Keep unauthorized personnel away from batteries.
2. When replacing batteries, use only models conforming to Battery Council International (BCI) 27 DC specifications for Group 27 Deep Cycle Marine batteries. At the time of this publication, the following model batteries are recommended. At the time of purchase, verify that these models, or any other model, conform to BCI 27DC specifications for Group 27 Deep Cycle Marine Batteries.  
  

<i>Die Hard</i>	<i>Model 27524</i>
<i>Exide</i>	<i>Model NC-27</i>
<i>Interstate</i>	<i>Model SRM-27</i>
<i>Metropolitan</i>	<i>Model 27T-36</i>
<i>NAPA</i>	<i>Model 8270</i>
3. **CAUTION – Do Not** dispose of batteries in a fire. The batteries might explode.
4. **CAUTION – Do Not** open or mutilate the batteries. Released electrolyte is harmful to skin and eyes
5. **CAUTION – A battery can** present a risk of electrical shock and high short circuit current. The following precautions should be observed when working on batteries.
  - A. Remove Watches, Rings, and other Jewelry and metal objects.
  - B. Use tools with insulated handles.
  - C. Do Not lay tools or metal objects on top of batteries.
  - D. Wear safety goggles and a face shield.
5. **CAUTION – The** electrolyte is a diluted sulfuric acid mixture that is Corrosive and harmful to the skin and eyes. It is also electrically conductive. Observe the following rules when working with the electrolyte solution.
  - A. Wear full eye protection and clothing.

B. If electrolyte comes in contact with the skin, wash it off immediately.

C. If electrolyte comes in contact with the eyes, flush thoroughly with water and seek medical attention immediately.

6. **CAUTION** – Lead acid batteries can present a risk of fire and explosion because they generate hydrogen gases. The

following precautions must be followed.

A. **Do Not** smoke when near batteries.

B. **Do Not** cause sparks or allow open flame in the battery area.

C. **Discharge static electricity** from your body and clothing before touching batteries by first touching a grounded surface.

**7. See Battery Manufacturers' installation manual for additional safety and maintenance instructions.**

## BATTERY BOX

Your selected battery should be stored in a high quality plastic or metal battery box with a lid that is designed for this purpose.

## LOCATION

- In a typical installation, the Pump Sentry should be mounted on the wall, above the sump pit or crock, and in accordance with all applicable local electrical codes.
- It should be in close proximity to a grounded AC outlet and the battery box (not closer than 2 feet).

## VENTILATION

- **Do Not** block either the fan or the exit air ports of the Pump Sentry. Allow at least 2 inches of air clearance on all sides. Any room in which the Pump Sentry is mounted should have adequate ventilation.

## UNDER NO CIRCUMSTANCES

**Should the Pump Sentry be mounted in a confined area or in a sump pump pit or crock.**

**WARNING! The Pump Sentry has several components with electrical contacts that switch electrical currents. Opening or closing any of these electrical contacts can produce a spark that could ignite an explosive air mixture. To prevent fire or explosion, do not install the Pump Sentry in a ny area which might contain flammable liquids or gases. Do not install Pump Sentry in the same confined area as the battery box.**

- Pump Sentry is not only an electrical appliance, but also produces a potentially dangerous and hazardous electrical current even when a power outage occurs. It is safe when installed and used properly. **Keep children away.**

## MAKING CONNECTIONS

After mounting Pump Sentry to the wall, follow these steps.

- Make sure the ON/OFF switch is in the OFF position.
- Connect the red battery cable to the Red (Positive) + terminal of the Pump Sentry.
- Connect the black battery cable to the Black (Negative) – terminal of the Pump Sentry.

**WARNING! DO NOT REVERSE THESE CONNECTIONS. DAMAGE TO THE PUMP SENTRY WILL OCCUR AND YOU WILL VOID THE WARRANTY.**

**WARNING! A spark may occur when connecting the second cable. This is normal. An explosion hazard may exist if flammable liquid or gas is present. INSTALL AND OPERATE PUMP SENTRY IN A WELL VENTILATED AREA ONLY.**

- Plug your pump into the Pump Sentry's AC outlet

- Plug the Pump Sentry into a 110 volt AC outlet
- Turn ON/OFF switch to the ON position.

## INSTALLATION TEST

- After making the connections as instructed above, cycle the pump to ensure its operation under normal conditions.
- Remove power cord from the AC wall outlet to simulate a power failure. The fan on the Pump Sentry should be turning and free of any blockage.
- Cycle the pump to ensure operation in “battery back up” mode.
- Plug the Pump Sentry AC power cord back into the wall outlet. Cycle the pump. Check to see if the internal fan on the Pump Sentry has stopped spinning. This is normal and is an indication that the Pump Sentry has recognized the return of normal AC power. The Pump Sentry is no longer in “battery back up” mode and has returned to its normal state of charging the battery.

## CHANGING THE BATTERY

If for any reason the battery needs changing, it is important to *follow the steps below, in the order shown* to avoid damage to the Pump Sentry unit.

1. Turn the ON/OFF switch on the Pump Sentry to the OFF position.
2. Unplug the input power cord of the Pump Sentry from the AC outlet.
3. Unplug the input power cord of the pump from the AC outlet on the Pump Sentry
4. Disconnect the batter cables from the batter. **CAUTION: MAKE SURE THAT THE PUMP SENTRY IS DISCONNECTED FROM AC POWER BEFORE DISCONNECTING BATTERY CABLES.**
5. Replace the battery.
6. Reconnect the Pump Sentry following the steps under the heading **MAKING CONNECTIONS.**

automatically recharge the battery when AC power returns. During all of these times and power transitions, the Pump Sentry requires no manual adjustments.

## MAINTENANCE

Once properly connected, the Pump Sentry requires no maintenance. When AC power fails, it will automatically convert battery power to AC power for operation of the pump. It will

**SPECIFICATIONS ARE SUBJECT TO CHANGE WITHOUT NOTICE.**



# Pump Sentry 812 PS, 1612 PS

Manufactured by  
SEC America, LLC  
S. Burlington, VT, 05407

## **Manufacturers Limited Warranty**

Pump Sentry is warranted to be free from defects in material and workmanship and to perform within applicable specifications for a period of one year after original shipment. Obligation under this guarantee is limited to repairing or replacing any part thereof, except fuses and pilot lights, which shall within one year returned to us with transportation charges prepaid, and prove after our examination to be thus defective.

The above limited warranties take the place of all other warranties, expressed or implied and correction of such defects by replacement or repair shall constitute a fulfillment of all obligations under the terms of the warranties. The warranties do not cover any unit, which has been damaged either in transit or by misuse, accident or negligence. No warranty or representation by anyone other than this Company shall be binding on us.

SEC America, LLC  
S. Burlington, VT 05407